



Manufacturer:

**Karl Klein
Ventilatorenbau GmbH**

Waldstr.24 D-73773 Aichwald

Tel.:
E-mail:+49-711-369060 Fax: +49-711-36906950
info@karl-klein.de <http://www.karl-klein.de>

Fan type:

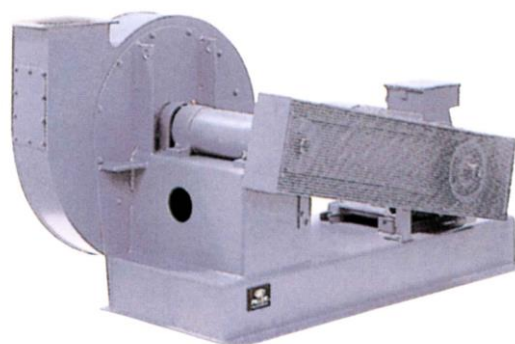
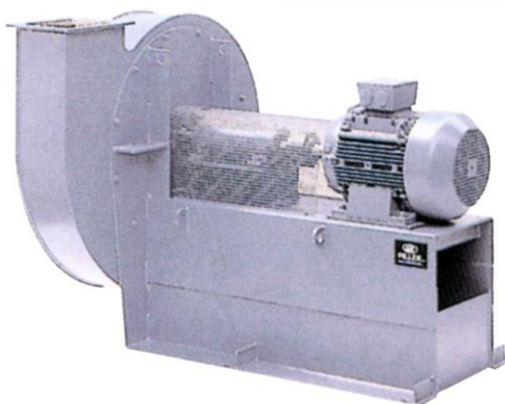
**NHV / NHVT / MHV / MHVT / HHV / HHVT / HF-...D
direct motor drive, ATEX version****NHVK / NHVKT / MHVK / MHVKT / HHVK / HHVKT / HF-...K
drive via coupling, ATEX version****NHVR / NHVRT / MHVR / MHVRT / HHVR / HHVRT / HF-...R
drive via V-belt, ATEX version****Fan and motor are suitable for operation in explosion protection zone:
1 (Cat. 2G), 2 (Cat. 3G), 21 (Cat. 2D) and 22 (Cat. 3D)**

**General conditions for the use of Karl Klein fans**

These general conditions set out the basic rules for the proper use of the fans. Where necessary they are supplemented by the information and specifications provided in the Installation instruction. The individual conditions are as follows:

- All maintenance instructions must be observed.
- All safety devices must be correctly installed.
- Changes to factory settings are not permitted without our approval.
- Only lubricants specified by the factory, or equivalent, may be used. Contamination is not permitted.
- If the machines are installed in a fixed position, the foundations must be expertly produced in accordance with DIN 4024, Part 2, and the machine secured in accordance with our recommendations.
- Reactive forces associated with connection of pipe lines must be restricted to a minimum, for example by using compensators. Where maximum loads for nozzles are specified in the dimension sheet, these must never be exceeded.
- No liability will be accepted for faults caused by inexpert placing into operation by the customer.
- Exceeding the maximum temperatures and speeds given in the specifications is not permitted even briefly.
- Foreign bodies are not permitted to enter the impeller.
- Only the substances (gas compositions) specified in the order are permitted to be conveyed. Any damages caused by non-specified media compositions are excluded from the warranty agreement.
- The fans may only be operated in a smooth-running condition. The permissible levels of bearing vibration are defined by the alarm and shut-down values specified in the Installation instruction.
- The alarm and shut-down functions on fans with vibration monitors must be in accordance with the limits specified in the Installation instruction. Operation above the alarm value is only permitted on a temporary basis for analysing the cause of vibrations. If the vibration values suddenly change for the worse, this may be a sign that the machine or part of the machine is at imminent risk of failure, jeopardising operational safety in the process. The causes have to be determined immediately and remedial action taken accordingly.
- Operation of the fans without vibration monitors is only permissible if the vibration levels do not exceed the limit values given in the Installation instruction (if no information is provided, 7.1 mm/s for fixed installation according to ISO 14694 BV-3; 4.5 mm/s for fixed installation according to ISO 14694 BV-4).
- Modifications to the impellers in connection with operational balancing of the customer have to be agreed with us. Any unauthorised measures shall render the warranty void.
- System-related swirling of the gas flow in the direction of rotation of the impeller must be prevented; counter-swirling is not permitted.
- Continuous operation is only permitted for the operating points specified in the order confirmation; in particular, operation with a closed slide valve or closed flow restrictor is only permitted for a short time (max. 5 minutes for start-up assistance).
- For fans with vane controllers, all fan controller positions require approval for operation, with the exception of a closed vane controller (90° or 0%). Operation with a closed vane controller is only permissible during start-up. The vane controller must be opened quickly as soon as the final speed has been reached. For applications with pressure increases in excess of 10kPa, the permissible vane controller positions in continuous operation must be restricted to a maximum of 70°.
- It is essential that the flow rate never falls below a minimum flow rate $V_{\min} = 0.3 * V_{\text{opt}}$ in continuous operation; for pressure increases greater than 20 kPa the minimum flow rate has to be raised to $0.5 * V_{\text{opt}}$ and operating points with pressure increases of less than 40% of the pressure increase in the design point have to be blocked.
- In the case of free intake, the inflow to the fan must be unimpeded. The minimum dimensions of the unimpeded rectangular space around the centre-point of the intake opening is $a = b = 2.5 * d$ (d = intake diameter).
- Heavy caking, corrosion and visible wear on impellers are inadmissible. Prevention measures must be agreed with us immediately.
- The surge-like entry of liquids into the impeller and inadequate removal of condensation from the fan housing must be prevented under all circumstances.
- If the motor is provided by the customer, we do not provide a warranty for design and function or for the operational safety of the coupling drive/belt drive in the event of electrical malfunctions (according to VDI 3840).
- The fans may only be started up when the machine is at a standstill.
- Where process temperatures are over 140°C, the fan is not permitted to be at a standstill because this may lead to damage to the bearings.
- Temperature gradients of more than 50°C/min are inadmissible, unless agreed otherwise.
- If fans are operated in parallel, operation to the left of the peak of the characteristic curve must be blocked.

ORIGINAL INSTALLATION INSTRUCTION



Installation instruction for
Karl Klein Radial Fan
Apovent ATEX version

Page3

GB

Version 07/2019

Transfer of PILLER housing positions to Karl-Klein housing positions

PILLER (Eurovent):
Clockwise (facing motor)

KARL KLEIN:
Anti-clockwise (facing intake)

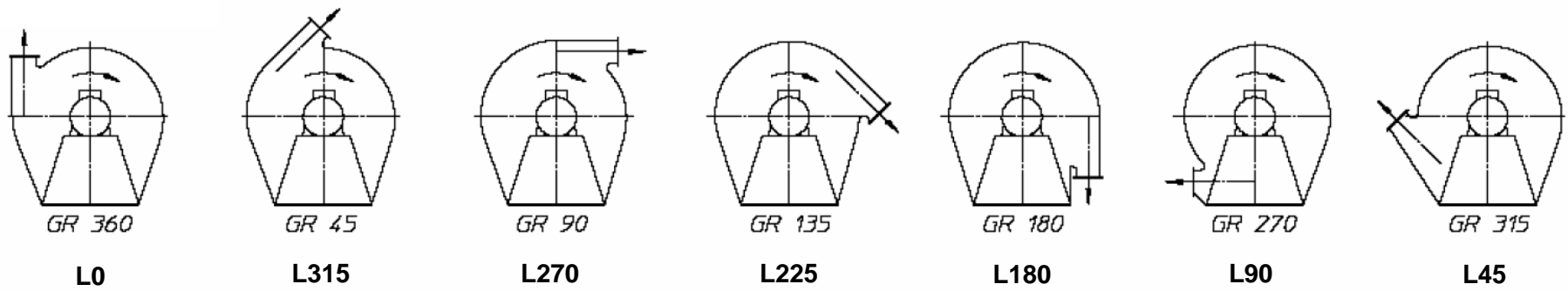

PILLER (Eurovent):
Anti-clockwise (facing motor) 1.

KARL KLEIN:
Clockwise (facing intake)

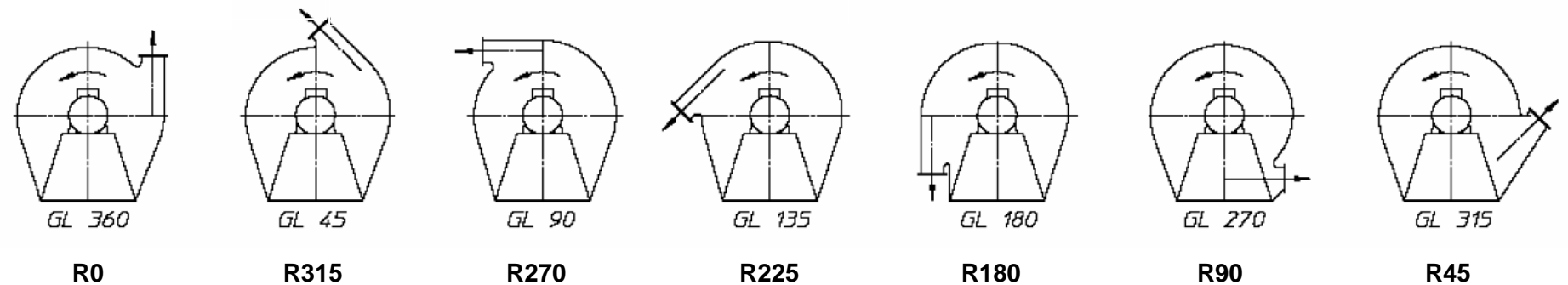



Table of contents

1	GENERAL INFORMATION.....	7
1.1	General description	7
1.2	Intended use.....	7
1.3	Declaration of indorporation of partly completed machinery	7
2	SAFETY INFORMATION	9
2.1	Symbols.....	9
3	LIMIT VALUES	12
4	NOTES AND INSTRUCTIONS ON SAFETY	12
4.1	Basic safety information.....	12
4.2	General notes and instructions on safety	12
5	SPECIALISTS.....	15
6	ELECTRICAL CONNECTION CONDITIONS	15
7	WARNINGS, LABELS	15
8	RESIDUAL RISKS	16
8.1	Overview of hazards	16
9	DESCRIPTION OF THE PRODUCT	18
9.1	Motor.....	18
9.2	Housing	19
9.3	Impeller	19
9.4	Shaft seal.....	19
9.5	Drive via coupling	20
9.6	Drive via V-belt	20
9.6.1	Bearing	20
9.6.2	Belt drive.....	20
10	ACCESSORIES (IF DELIVERED)	21
10.1	Compensators (with / without guide plate)	21
10.2	Vibration dampers.....	21
10.3	Flanges	21
11	ITEMS SUPPLIED AND TEMPORARY STORAGE.....	22
12	INFORMATION ON TRANSPORTATION.....	22



12.1	Safety information for transportation	23
12.2	Transport instructions	24
12.2.1	Direct drive	24
12.2.2	Drive via coupling	25
12.2.3	Drive via V-belt	26
13	INSTALLATION	27
14	PLACING INTO OPERATION / TEST RUN	28
15	SWITCHING ON THE FAN	29
16	SWITCHING OFF THE FAN	29
17	SERVICING AND MAINTENANCE	30
17.1	Motor	31
17.2	Housing	31
17.3	Impeller	32
17.4	Shaft seal	32
17.5	Disassembly/assembly of the impeller	32
17.6	Drive via V-belt	33
17.6.1	Bearing	33
17.6.2	Disassembly/assembly of the roller bearings	33
17.6.3	Belt drive	34
17.7	Drive via coupling	35
17.7.1	Coupling drive	35
17.7.2	Disassembly/assembly of the roller bearings	35
17.8	Compensators with / without guide plate	37
17.9	Tightening torque	37
17.10	Checking the screw connections	37
17.11	Checking for leaks	37
17.12	Storage and corrosion protection instructions	38
17.12.1	Removal of protection against corrosion	38
18	FAULTS AND TROUBLESHOOTING	39
18.1	Drive via coupling	40
18.2	Drive via V-belt	41
19	DISASSEMBLY	42



20	DISPOSAL.....	42
21	SPARE PARTS.....	43
22	EC-DECLARATION OF INCORPORATION OF PARTLY COMPLETED MACHINERY	44
23	EC-DECLARATION OF CONFORMITY ATEX FOR THE NONELECTRICAL PART	45



1 General Information

1.1 General description

The partly completed machine described in this Installation instruction is a welded radial fan. The term radial fan refers to machines used to convey air, air-like gases or gas mixtures. Radial fans operate on the basis of centrifugal force. The air therefore flows into the fan parallel to the axis of rotation, but is then deflected at right-angles before it enters the impeller and is thrown out to the outside by centrifugal force. The term radial fan is derived from the fact that the medium moves on a radius of the impeller after it has been deflected.

The fan is normally comprised of the following components:

- Housing with openings on the intake and pressure sides
- Impeller in a housing, mounted on a shaft
- Stand, which supports the housing, bearing unit and drive unit (motor)
- As a general rule, pipe lines supplied by the customer and fitted to the openings on the intake and pressure sides



A fan in the case of the present application is a flow machine which is subjected to high dynamic loads and may only be operated by qualified personnel!

1.2 Intended use

The fan is designed exclusively for conveying the medium specified in the data sheet/order documents for the machine, and subject to the operational parameters specified therein. Any use beyond the aforementioned use and any deviation from the operational parameters which exceeds the general safety instructions, shall be regarded as improper use. The manufacturer shall not be liable for any damages resulting from such improper use. In this case the risk is borne solely by the user.

The definition of intended use also encompasses observing the operating, maintenance and servicing conditions specified by the manufacturer.

The fan may only be operated, serviced and repaired by persons who are familiar with it and have been informed about its potential hazards.

The applicable accident prevention regulations and all other generally recognised rules relating to health and safety at work and road traffic must be complied with.

The manufacturer will not be liable for any damages resulting from unauthorised modifications to the machine.

1.3 Declaration of incorporation of partly completed machinery

The fan described in this Installation instruction conforms with the safety and health requirements of European Machinery Directive 2006/42/EC. If properly installed and maintained and used in accordance with the intended use it will not compromise the health or safety of persons or the safety of property.

With an Declaration of incorporation of partly completed machinery based on EC Directive 2014/34/EC we declare that the non-electrical equipment described in this Installation instruction conforms with the regulations of the EC Directive 2014/34/EC.

The equipment is driven by an electric motor whose conformity has been declared separately by the supplier/stipulated office.



It is essential that you read the "Safety instructions" chapter in this Installation instruction before placing the fan into operation.



Before placing the fan into operation for the first time and each time it is started up again after inspection and maintenance work, it has to be ensured that all foreign bodies, tools, scaffolding and auxiliary equipment have been cleared from the fan housing and downstream ducts.



All safety equipment such as emergency stop switches, shaft protection, coupling protection, etc., must be installed.



Cordon off the fan's danger zone to unauthorised persons over a wide area and switch on the fan from a safe distance.



Persons, animals or loose objects must never be allowed to stand in the air flow or be suctioned in!
The air flow generated by the fan can be so powerful that it is capable of sucking in or blowing away a human body or heavy objects.



It is imperative that all supplied and agreed/provided safety devices such as temperature, vibration and speed monitors, etc., are connected and also checked to ensure that they are in perfect working order at all times.



2 Safety information

2.1 Symbols

Symbols are used in this Installation instruction and on the fan which must be given special attention:



This draws attention to hazardous situations involving a risk of personal injury and damage to property.

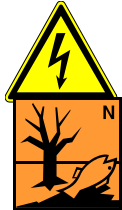

Risk of danger from electricity. Work to be carried out may only be carried out by an electrician.

Information relating to protection of the environment



Beware of risk of injuries to hands



Beware of suspended loads



Beware of hot surfaces



Beware of rotating parts



Beware of caustic substances



Beware of fall hazard



Beware of harmful substances

ORIGINAL INSTALLATION INSTRUCTION



Installation instruction for
Karl Klein Radial Fan
Apovent ATEX version

Page10

GB

Version 07/2019



Beware of potentially explosive atmosphere



Beware of toxic substances



Slings points for transporting the fan

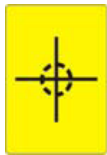

Centre of gravity of the fan



Manual arc welding prohibited on the fan



No access for persons



Read this Installation instruction before placing into operation



Wear ear protection



MANDATORY REQUIREMENT Observe instructions!
It is imperative that the specified safety instructions must be observed.



MANDATORY REQUIREMENT Wear ear protection!
Ear protection must be worn for all work on the system.



MANDATORY REQUIREMENT Wear safety footwear!
Safety footwear must be worn for all work on the system.



MANDATORY REQUIREMENT Wear gloves!
Suitable safety gloves must be worn for all work on the system.



MANDATORY REQUIREMENT Wear safety glasses!
Safety glasses must be worn for all work on the system.



3 Limit values

Limits for which operation of the fan must be stopped:

Bearing temperatures

Alarm $\geq 90\text{ }^{\circ}\text{C}$ (The fan can continue to be operated)

Shut-down $\geq 100^{\circ}\text{C}$ (The fan must be switched off immediately)

Machine vibrations

Measured at the bearing points

Alarm: $\geq 4,5\text{ mm/s}$ (Check the fan as quickly as possible)

Shut-down: $\geq 7,1\text{ mm/s}$ (The fan must be switched off immediately)

4 Notes and instructions on safety

4.1 Basic safety information

The fan has been constructed in accordance with the latest state-of-the-art in technology and approved technical rules concerned with safety. Nevertheless, it may still be a source of danger to the life and limb of the operator or other persons during operation, or of impairment to the machine and other items of property.

The fan must only ever be used in perfect technical condition, in accordance with the intended use and with proper regard for safety and dangers and the instructions in the Installation instruction. In particular, any faults which compromise safety must be eliminated immediately.

4.2 General notes and instructions on safety

- 4.2.1 In addition to observing the notes and instructions contained in this Installation instruction, you must also observe the general regulations concerned with safety and the prevention of accidents.
- 4.2.2 The owner-user is responsible for ensuring that the machine is only used when it is in perfect working order.
- 4.2.3 Changes to factory settings are not permitted without our approval!
- 4.2.4 The fans may only be started up when the machine is at a standstill.
- 4.2.5 Exceeding the maximum temperatures and speeds given in the data sheet is not permitted even briefly!
- 4.2.6 Before connecting up the electrical connections of the motor, the manufacturer's instructions relating to safety and commissioning and the requirements of DIN VDE 0105 or IEC 364 must be taken into account!
- 4.2.7 If motors or frequency converters are supplied, we do not provide a warranty for design and function or for the operational safety of the coupling. In the case of drives with frequency converters, the motor data according to the motor rating plate must be entered and the converter must be used as a speed regulating rheostat and not as a speed controller. Incorrect parameterisation can lead to the destruction of the coupling!
- 4.2.8 Modifications to the impellers in connection with operational balancing of the customer have to be agreed with us.
- 4.2.9 It must be ensured that fluids or dissimilar materials are prevented from getting into the fan to the extent that they can be conveyed by the impeller! If any fluids are conveyed, this will damage the impeller beyond repair! Provision must be made to ensure that condensate is effectively removed from the fan housing!
- 4.2.10 Caking, corrosion and visible wear on impellers are inadmissible! Prevention measures must be agreed with us immediately!
- 4.2.11 System-related swirling of the gas flow in the direction of rotation of the impeller must be prevented; counter-swirling is not permitted!
- 4.2.12 It is essential that the flow rate never falls below a minimum flow rate $V_{\min} = 0.3 * V_{\text{opt}}$ in continuous operation; for pressure increases greater than 20 kPa the minimum flow rate has to be raised to $0.5 * V_{\text{opt}}$ and operating points with pressure increases of less than 40% of the pressure increase in the design point have to be blocked! The impeller will be damaged beyond repair if the fan is operated for longer periods at below specified flow rates! Short operating states (start-up and shut-down) of less than 5 minutes duration per day are permissible!
- 4.2.13 The cleaning opening on the fan housing may only be opened when the machine is at a standstill! The fan must be secured to prevent it starting up again during this time!



- 4.2.14 The fans may only be operated in a smooth-running condition. The permissible levels of bearing vibration are defined by the alarm and shut-down values specified by Karl Klein Ventilatorenbau GmbH if vibration monitors are provided.
- 4.2.15 The alarm and shut-down functions must be in accordance with the limits specified in the Installation instruction. Operation above the alarm value is only permitted on a temporary basis for analysing the cause of vibrations! If the vibration values suddenly change for the worse, this may be a sign that the machine or part of the machine is at imminent risk of failure, jeopardising operational safety in the process! The causes have to be determined immediately and remedial action taken accordingly!
- 4.2.16 Operation of the fans without vibration monitors installed is only permissible if the vibration levels in the bearing planes do not exceed a maximum value of 7.1 mm/s (Group 3, Zone Limit B/C according to DIN ISO 10816-3)! For an optimum machine service life, the maximum vibration levels should be restricted to 4,5 mm/s! Process-relevant fans need to have their vibration levels checked and documented at regular intervals (every 14 days as a minimum).
- 4.2.17 Fan components which may be touched accidentally during normal fan operation, and drive or supply systems with an external surface temperature of over 65°C or below minus 12.5°C must be protected, insulated or provided with warnings (see DIN EN 563).
- 4.2.18 Electrical and mechanical safety equipment provided by the customer must comply with the requirements of DIN EN 60204-1, DIN EN ISO 13857 and DIN EN 349. Cables must be properly fitted and protected and sufficiently insulated.
- 4.2.19 The electrical installation must meet the requirements of DIN EN 50154.
- 4.2.20 The build up of electric charges must be prevented by the earthing of components. Compliance with DIN EN 50081 Parts 1 and 2 is required.
- 4.2.21 To prevent the risk of ignition due to electrostatic charging, the requirements on external components must be taken into account (see DIN EN 1127-1).
- 4.2.22 Electric equipment must conform with DIN EN 50014.
- 4.2.23 Fans in potentially explosive areas must be adequately protected against unacceptable increases in temperature. It must be ensured that the minimum gap width between static and rotating components is not underranged by the thermal effects which arise during operation.
- 4.2.24 It must be ensured that no risk of explosion arises due to the materials or substances used.
- 4.2.25 It must be ensured that no risk of explosion arises due to escaping medium.
- 4.2.26 The pipe lines and the housing must be inspected at regular intervals to check for the presence of foreign bodies. These must not be permitted to get into the inside of the fan.
- 4.2.27 The fan may only be operated with pipe lines connected or the use of mesh guards. Mesh guards in front of the intake opening for free intake must not be capable of being removed using tools.
- 4.2.28 The system must be protected against lightning strikes by surge arresters (see DIN EN 1127-1).
- 4.2.29 The possibility of ignition through radio transmission systems or high-frequency generators must be taken into account (see DIN EN 1127-1).
- 4.2.30 The possibility of ignition through the absorption of focussed radiation such as light or lasers must be taken into account (see DIN EN 1127-1).
- 4.2.31 The possibility of ignition through ultrasonic echo testers must be taken into account (see DIN EN 1127-1).
- 4.2.32 The possibility of ignition through radiation from X-ray tubes or radioactive materials must be taken into account (see DIN EN 1127-1).
- 4.2.33 Suitable protective measures must be taken when conveying materials which are liable to spontaneous combustion.
- 4.2.34 The ignition of e.g. lubricating oil mist must be prevented by using gates and valves which open and close slowly.
- 4.2.35 The fan must be examined for transport damage before it is placed into operation and must not be placed into operation if there is any damage.
- 4.2.36 Ventilated air flow at fan inlet with higher or lower values than the specified limits of 0.8 to 1.1 bar for absolute pressure and -20°C to +60°C for temperature are not permitted, max. allowed oxygen content is 21 volume percent.
- 4.2.37 Ambient atmospheres with higher or lower values than the specified limits of 0.8 to 1.1 bar for absolute pressure and -20°C to +40°C for temperature are not permitted, max. allowed oxygen content is 21 volume percent.
- 4.2.38 Restoring forces from pipe lines must be restricted to a minimum by using compensators.
- 4.2.39 On indirectly driven fans change the bearings after 20000 operating hours as preventive maintenance.
- 4.2.40 On belt-driven machines change the belts after 10000 operating hours as preventive maintenance.
- 4.2.41 On coupling machines the maximum permissible surface temperatures must not be exceeded during engagement and disengagement.



- 4.2.42 Change the bearings after 10000 operating hours as preventive maintenance. With regard to changing motor bearings as preventive maintenance be sure to consult the Installation instruction issued by the motor manufacturer.
- 4.2.43 The maximum permissible motor bearing temperatures are not allowed to be exceeded and must be regularly checked.
- 4.2.44 The machine may only be operated if guards are installed, using the original means of fastening.
- 4.2.45 Manual welding work on the fan is prohibited and will unavoidably render the warranty void.
- 4.2.46 If buffer gases are used on shaft exits, they must not be harmful. They must be compatible with the medium and must not corrode, modify or break down any of the existing materials.
- 4.2.47 Controllers for speed-controlled drives have to be set so that there is no possibility of resonance with the resonant frequencies of the mechanical system.
- 4.2.48 Guide mandrels must be used for installation and maintenance work.
- 4.2.49 Appropriate precautions must be taken against falling when carrying out maintenance and repair work.
- 4.2.50 Operation on a 60Hz mains system is not permitted for 50Hz machines.
- 4.2.51 To prevent electric shocks caused by contact with live parts, connect metal cable ducts and cable sheaths to the protective conductor system.
- 4.2.52 Ensure that the incoming feeder is switched off automatically by overcurrent and earth-leakage circuit-breakers.
- 4.2.53 Incorrect displays and malfunctions on the monitoring and control systems caused by interference from electromagnetic fields in the signal cable or power supply cables must be prevented by sufficient shielding, including in the control cabinets.
- 4.2.54 It is imperative that ear protection be worn for noise emissions of 85 dB(A) and over.
- 4.2.55 The customer must provide adequate illumination for the work area for all maintenance and servicing work.
- 4.2.56 If operated on a frequency converter, the maximum speed must be locked.
- 4.2.57 An automatic restart after the power supply has been restored is inadmissible and must be prevented.
- 4.2.58 The customer must provide and use lockable central switches and install emergency stop switches.
- 4.2.59 Lubrication of the bearings must be ensured by strict observance of lubrication regulations and regular maintenance, including checking the bearing temperatures.
- 4.2.60 Maintenance must be carried out at regular intervals in accordance with our Installation instruction!



5 Specialists

The work of placing into operation may only be carried out by specialists who, on the basis of their professional training, experience and instruction, have sufficient knowledge of:

- Safety regulations
- Accident prevention regulations
- Directives, guidelines and generally recognised codes of practice

The specialists must:

- be assigned/contracted to do the work by the company;
- be capable of assessing the work they have been assigned/contracted to do;
- be capable of recognising and preventing or avoiding potential hazards;
- be authorised to undertake the necessary work and activities by the individual responsible for safety.

Only deploy reliable and trained personnel who have been familiarised with the work. Only qualified electricians (according to the definition of specialists in DIN VDE 0105 and IEC 364) are permitted to carry out any work or checks on electrical components!

This must be in compliance with the valid, applicable:

- national regulations;
- Safety regulations
- accident prevention regulations.

The applicable regulations (VDE, etc.) relating to the handling of electrical equipment, e.g.

- disconnection;
- securing to prevent equipment being switched on again;
- verifying that equipment is disconnected from the power supply;
- earthing and short-circuiting;
- covering or safeguarding of adjacent live components,

must be complied with.

Electricians are defined as persons who, on the basis of their professional training, experience and instruction, have knowledge of the applicable standards, regulations and accident prevention regulations. They must also be capable of assessing the work they have been assigned to do and recognising potential hazards.

6 Electrical connection conditions

For the connection of the electrical components, the valid, applicable national standards apply. In this connection it is important to ensure that the regulations of the relevant power supply companies are also taken into account.



Only qualified electricians (according to the definition of specialists in DIN VDE 0105 and IEC 364) are permitted to carry out any work or checks on electrical components!

7 Warnings, labels

All information signs affixed to the fan (such as slinging points, centre of gravity positions, direction of rotation arrows, plus possible information relating to lubrication and belt drives) must be observed and kept in a legible condition.

ORIGINAL INSTALLATION INSTRUCTION



Installation instruction for
Karl Klein Radial Fan
Apovent ATEX version

Page16

GB

Version 07/2019

8 Residual risks

The residual risks listed below still remain in spite of the measures taken with regard to the integration of safety in the design, and in spite of the safety precautions and the supplementary safety measures taken, and must therefore be given special attention.

8.1 Overview of hazards

Type of hazard	Danger	Danger area	Action
Crush injuries/damage due to falling parts / machines	Fatal injury, damage to property	Installation and assembly	Observe transport instructions
Shearing when installing machine components	Risk of injury	Installation and assembly	Observe the Installation instruction; use guide mandrels
Drawing into the fan housing	Fatal injury	Intake opening	Observe the Installation instruction; observe safety distances
Parts of the body and clothing getting drawn into the drive elements	Risk of injury, damage to property	All rotating parts	Observe the Installation instruction; do not remove safety equipment
Loss of stability	Risk of injury, damage to property	Transportation and operation	Observe the Installation instruction; observe transport instructions; proper transportation; proper foundations and fastening
Slipping, falling	Risk of injury	Installation and assembly and maintenance	Observe the Installation instruction; take appropriate measures against falling and crashing
Electric shock	Fatal injury	Direct danger from contact with live parts; indirect danger from faulty live parts	Observe the Installation instruction; observe safety regulations
Electric shock caused by electrostatic discharge	Fatal injury	Contact during operation	Observe the Installation instruction; observe safety regulations; earth the housings
Burn or freezing injuries due to hot/cold machine components	Risk of injury; Risk of explosion due to increased risk of ignition	Hot/cold machine components	Observe the Installation instruction; marking; Wear safety equipment
Loss of hearing or physiological impairment due to machine noise	Risk of injury	Noise levels over 70 dB(A)	Observe the Installation instruction; marking; Wear safety equipment

ORIGINAL INSTALLATION INSTRUCTION



Installation instruction for
Karl Klein Radial Fan
Apovent ATEX version

Page17

GB

Version 07/2019

Type of hazard	Danger	Danger area	Action
Danger due to materials and other substances	Risk of injury, damage to property	Installation, assembly, maintenance and operation	Observe the Installation instruction; Prevent foreign bodies from entering; provide sufficient ventilation; marking; Wear safety equipment
Combination of hazards	Risk of injury, fatal injury, damage to property, harm to the environment	Inexpert installation and placing into operation; operating errors	Observe the Installation instruction
Unexpected start-up	Fatal injury	Maintenance, repair	Observe the Installation instruction; observe safety regulations; lockable central switch
Escaping high-pressure fluid - buffer fluids on shaft seals	Risk of injury	Maintenance and operation	Observe the Installation instruction; observe safety regulations; limitation of buffer fluid connection pressure
Inadequate monitoring	Risk of injury, damage to property	Operation	Observe the Installation instruction; observe safety regulations; connection and activation of monitoring functions
Impeller breakage, parts catapulting out	Risk of injury, fatal injury, damage to property, harm to the environment	Fan housing, operation	Observe the Installation instruction; observe safety regulations; proper use



9 Description of the product

9.1 Motor

General information

There are live parts and rotating parts on the inside of the electric motors. All connection, commissioning and maintenance work must therefore be carried out as a general rule by qualified specialists in accordance with the information and specifications provided by the manufacturer. The requirements of DIN VDE 0105 or IEC 364 must be complied with. If not, there is a risk of causing serious personal injury and damage to property. The valid, applicable national, local and system-specific regulations and requirements must be observed.

Intended use

The motors have been designed in accordance with DIN VDE 0530.

The use of motors in potentially explosive areas falling under danger zone 1 is not permitted without certification of conformity (observe supplementary instructions).

The power rating given for the motors is for ambient temperatures up to +40°C and for installation altitudes = 1000 m above sea level. Use under other ambient conditions may be possible under certain circumstances subject to consultation with the manufacturer of the motor or fan.

Electrical connection



Connection may only be carried out with the system disconnected from the power supply.
The system must be secured to prevent it being switched on again!
In particular, the fan must also be secured to prevent it being started up again accidentally.

The information on the rating plate, the connection diagram in the connection box and the additional information in the Installation instruction of the manufacturer must be observed.

To ensure that the electrical connection provides lasting safety, the connection work must be carried out in accordance with the motor manufacturer's Installation instruction.

Observe the tightening torques for the terminal board connections. These can be found in the motor manufacturer's Installation instruction.

It must be ensured that neither foreign bodies and dirt or moisture get into the terminal box. Cable inlets which are not required need to be sealed off with blank plugs to make them dust-tight and watertight. When you close the terminal box, make sure that the seal on the cover of the terminal box is fitted correctly.

The mains voltage and mains frequency must be identical with the values given on the rating plates for the motor. Motors with wide voltage winding can be operated with different mains voltages. In this case you have to check whether the available mains voltage is covered by the voltage range given on the motor's rating plate. Where 60 Hz mains systems are concerned, an additional plate may be attached by the fan manufacturer which tells you that the motor may also be operated with 50 Hz on a 60 Hz mains system.



The arrangement of the jumpers on the terminal board is dependent on the available mains voltage (see illustration).

Winding circuit in

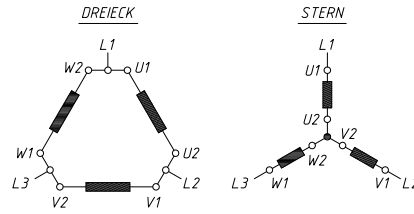

Positions of the jumpers on the terminal board

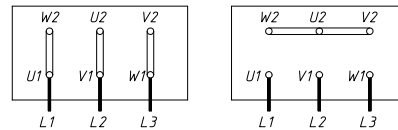

Two examples for winding constructions and operating voltages:

Winding construction 230 V:

Operating voltage:	230 V	/	400 V	50 Hz
			460 V	60 Hz /
	220-240 V		380-420 V	50 Hz
			440-480 V	60 Hz

Winding construction 400 V:

Operating voltage:	400 V	/	690 V	50 Hz
	460 V			60 Hz /
	380-420 V		660-725 V	50 Hz
	440-480 V			60 Hz

The protective earth conductor has to be terminal.



connected to the

9.2 Housing

The housing is a welded construction with flanges on the intake and pressure sides.

The housing has a housing cover opening in order to enable removal.

The cleaning opening or inspection opening (if provided) is positioned on the circumference of the fan housing. It may be opened only when the machine is at a standstill! The fan must be secured to prevent it starting up again during this time. The condensate drainage nozzle (if provided) is located at the lowest point on the housing and is sealed with a shut-off valve, plug, cap or dummy flange. Before placing into operation and during operation, the nozzle has to be opened if necessary to allow any condensation which has collect to drain away. Never allow the impeller to start up in condensation as this could lead to damage and unbalance.

9.3 Impeller



The maximum permissible speed (specified on the rating plate on the fan) must never be exceeded under any circumstances!

9.4 Shaft seal

The fan housing seal at the shaft exit is comprised of one or several sealing washers which are held by metal adapters. The seal is bolted to the rear wall of the fan and a small radial gap is formed. Leakage losses are to be expected.



9.5 Drive via coupling

In the KHV product series, the drive system acts via a coupling.

Make	Coupling type / size
N-Eupex	B 80, B 95, B 110, A 125
Fenaflex	F 80, F 100, F120

The fan shaft is supported by a double-bearing casing with grease lubrication. The fan shaft is supported at two bearing points which are both mounted together in a single bearing casing.

Never exceed the stipulated bearing temperature!

The bearings are designed for a mathematical minimum service life of 40000h! This service life will be achieved only if maintenance is performed in accordance with our maintenance manual and the machine is operated only within the specifications set out in the Technical Data Sheet!

9.6 Drive via V-belt

9.6.1 Bearing

The fan shaft is supported by a double-bearing casing with grease lubrication. The fan shaft is supported at two bearing points which are both mounted together in a single bearing casing.

Never exceed the stipulated bearing temperature!

The bearings are designed for a mathematical minimum service life of 40000h! This service life will be achieved only if maintenance is performed in accordance with our maintenance manual and the machine is operated only within the specifications set out in the Technical Data Sheet!

9.6.2 Belt drive

The drive system acts via a V-belt drive.

The belts are electrically conductive in accordance with ISO R 1813 and thermally resistant from -55°C to +70°C.

Where V-belt drives are used, the following requirements must be met:

- Before placing into operation, the V-belts have to be re-tensioned to the values stipulated above!
- The V-belts have to be checked after a short running-in period of about 15 minutes and re-tensioned if necessary.
- Check the V-belt after 3 days under operating conditions and re-tension if necessary.
- Check the V-belt after 10 days under operating conditions.
- The belt tension needs to be checked at greater intervals on a regular basis.

A belt testing device must be used for testing and tensioning.



10 Accessories (if delivered)

10.1 Compensators (with / without guide plate)

Compensators are used to isolate the fan from the system in terms of vibrations. Axial, angular and lateral movements can be absorbed.

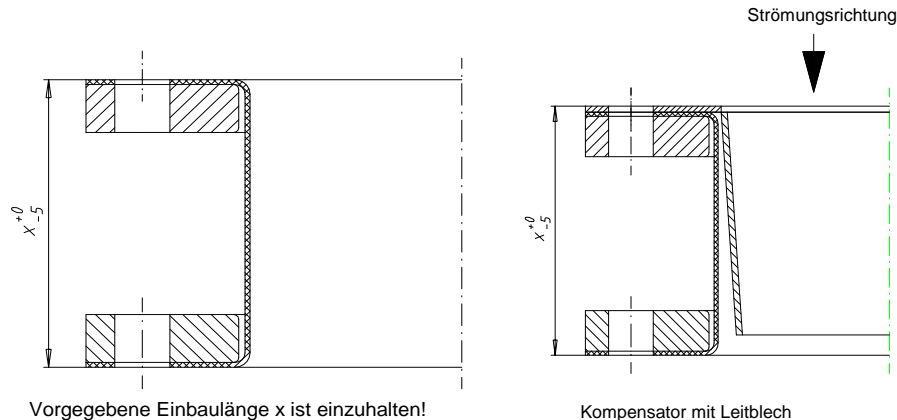

very small

are not allowed to arise or the guide plate may damage the compensator bellows. A guide plate is installed to protect the compensator against abrasion and for flow-related reasons.

Compensators with a guide plate can absorb only lateral and axial movements. Angular movements



The permissible forces, moments, distances and angles stipulated on the dimensions sheet are not allowed to be exceeded!

The mounting dimensions of the compensators (see the dimensions sheet or the data sheet) must be observed!

10.2 Vibration dampers

The supplied vibration dampers are used for the low-vibration installation of the fan on the foundation. They must be fitted underneath the fan at the points marked in the dimensions sheet and be fastened to the foundation (dowels). The vibration dampers have a degree of insulation which enables the machine vibrations originating from the unbalance forces to be suppressed by approx. 90%. The resonant frequency of the vibration dampers lies at approx. 250 to 300 min⁻¹. Increased unsteady running may occur therefore in the machine entrance or exit. The rubber parts must be protected against oil, petrol and seawater. During installation it is important to remember that the elements may expand to the side. The ambient temperature should not exceed +70°C. Proper operation of the vibration dampers is assured only when movement is unobstructed. It is important therefore to keep foreign bodies out of the fan's surroundings.

10.3 Flanges

The supplied flanges are for welding onto the customer-end pipe lines so that they can be connected to the fan. The connecting bolts are supplied.

**11 Items supplied and temporary storage**

Check the delivery for completeness in accordance with the delivery note when it arrives. Any missing parts and/or transport damage must be reported immediately in writing.

The fan has to be protected against penetration by moisture and dust and against inadmissible vibrations from the foundations. Measures must be taken to prevent the influence of strong fluctuations in temperature. Failure to observe the above could lead to damage to electric motors, cable terminal boxes, bearings, coats of paint and seals, etc., as well as corrosion, and therefore a higher risk of ignition as a consequence.
For temporary storage the fan must be stored in its transportation packing.

12 Information on transportation

Only the provided and marked transport eye-bolts and/or lifting lugs are allowed to be used for moving and lifting the fan and accessories, with due consideration for the centre of gravity positions.

Lifting tackle and slings must be in perfect condition and are allowed to be fastened only to the provided transport eye-bolts and/or lifting lugs.

The slinging points for the transport phase are marked with the following symbol at the individual transport eye-bolts:



Other slinging points, e.g. on the housing and motors, for the repair and maintenance phases are closed with plastic caps and are not allowed to be used for the transport phase.

The centre of gravity position is marked with the following symbol on the fan:

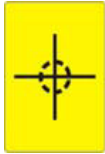

The fan may only be lifted and transported by persons who have read this Installation instruction, have understood the specified safety regulations, accident prevention regulations and instructions concerning the transportation of the fan, and are familiar with the hoisting, the required lifting tackle and the slings.

**12.1 Safety information for transportation**

Observe the safety information for transportation!

- Transportation and lifting on site is the responsibility of the customer and should be carried out by qualified personnel.
- Accident prevention regulations must be complied with.
- Do not move the load over people.
- The fans may only be lifted and transported by the fixtures provided for the purpose.
- If the hoisting gear has sufficient load capacity, it can be used to lift the complete fan for transporting on site.
- Carrying ropes are allowed to be fastened only to the provided holding points.
- Care must be taken when lifting the fan to ensure that no parts get damaged by the carrying ropes. Use a carriage if necessary!
- Prevent the fan from bumping into anything, as this will cause damage.
- The carrying ropes and harnesses must be suitable for the weight of the fan.
- Do not let the fibre ropes get tangled.
- Do not let ropes and chains get twisted.
- Suspension elements must be able to move freely on the load hook.
- Wear personal protective equipment (helmets, gloves, etc.).
- Transport eye-bolts on motors and housings must not be used for lifting the fan as a complete unit.
- The fan has to be lifted and lowered gently in order to avoid causing any damage.
- The manufacturer cannot accept any liability for damages caused by transportation on site.



12.2 Transport instructions

12.2.1 Direct drive



Lift and transport the fan using suitable lifting tackle and slings only, at the transport eye-bolts and/or lifting lugs intended for the purpose!
Observe the following diagram!

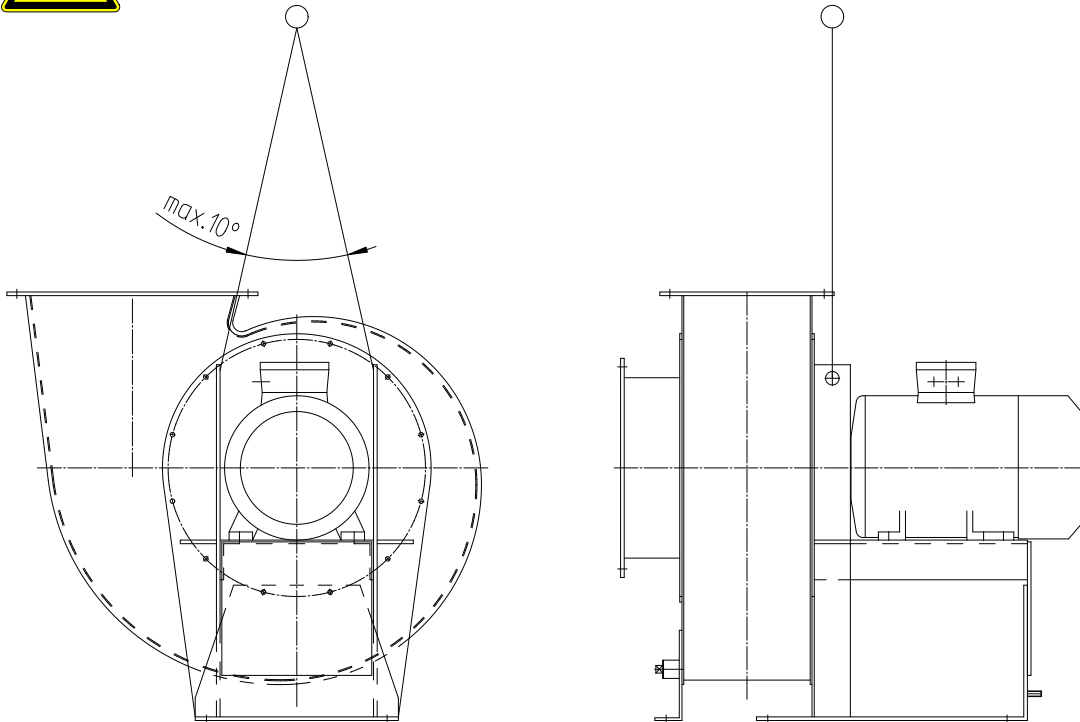

- The fans may only be lifted and transported by the fixtures provided for the purpose. Do not attach lifting tackle and slings to bearings, intake and pressure nozzles, motors or other components!
- It is imperative that you make sure that you use lifting tackle and slings with the same lengths and that the weight is distributed evenly. The angle must not exceed 10°! See the previous diagram.
- Care must be taken when lifting the fan to ensure that no parts get damaged by the lifting tackle and slings. Use a carriage if necessary!

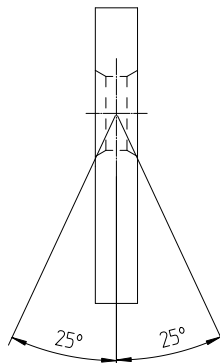
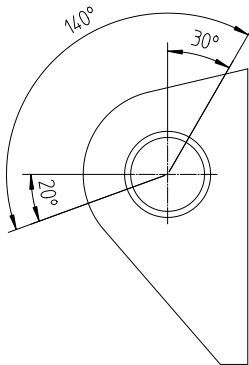

Permissible load directions



12.2.2 Drive via coupling



Lift and transport the fan using suitable lifting tackle and slings only, at the transport eye-bolts and/or lifting lugs intended for the purpose!
Observe the following diagram!

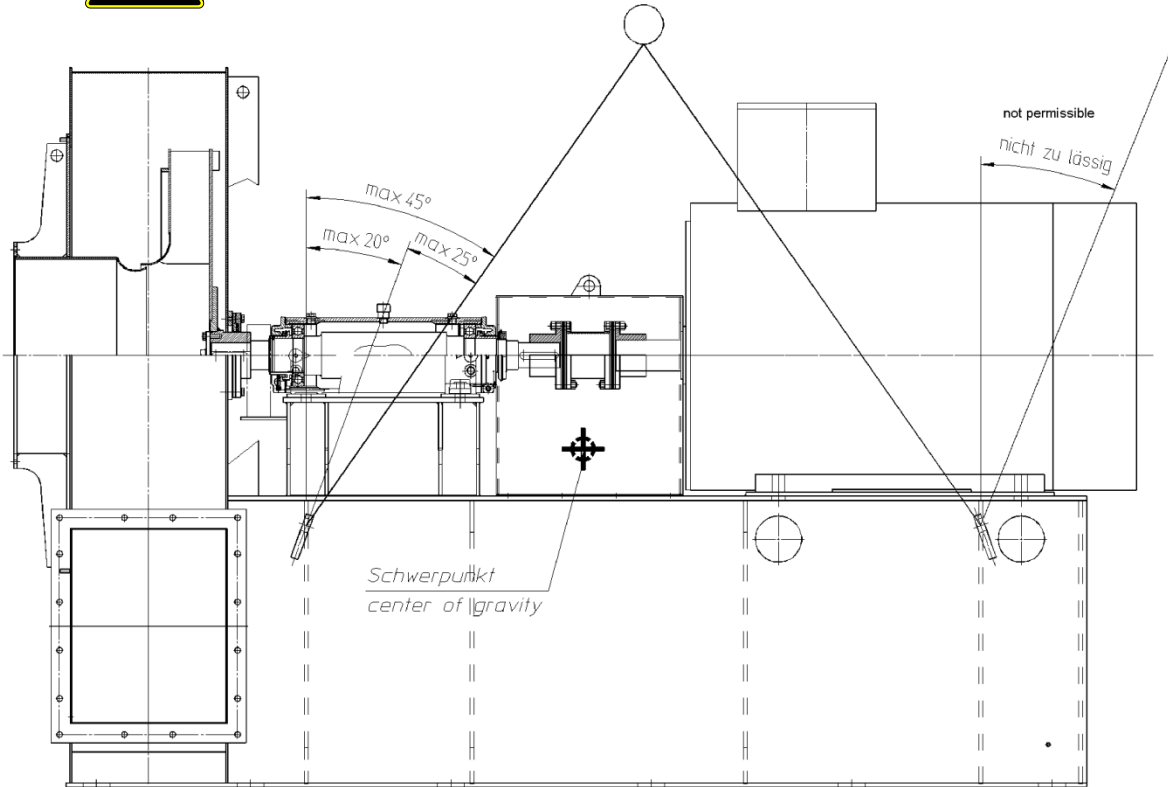

- The fans may only be lifted and transported by the fixtures provided for the purpose. Do not attach lifting tackle and slings to bearings, intake and pressure nozzles, motors or other components!
- It is imperative that you make sure that you use lifting tackle and slings with the same lengths and that the weight is distributed evenly. The angle must not exceed 45°! See the previous diagram.
- Care must be taken when lifting the fan to ensure that no parts get damaged by the lifting tackle and slings. Use a carriage if necessary!

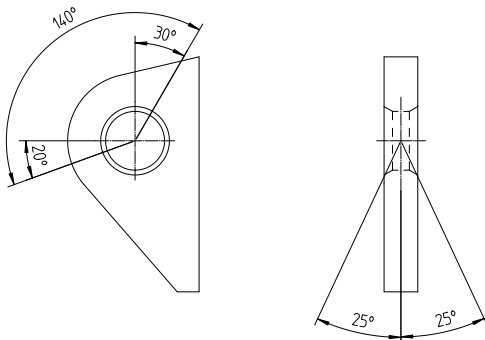

Permissible load directions



12.2.3 Drive via V-belt



Lift and transport the fan using suitable lifting tackle and slings only, at the transport eye-bolts and/or lifting lugs intended for the purpose!
Observe the following diagram!

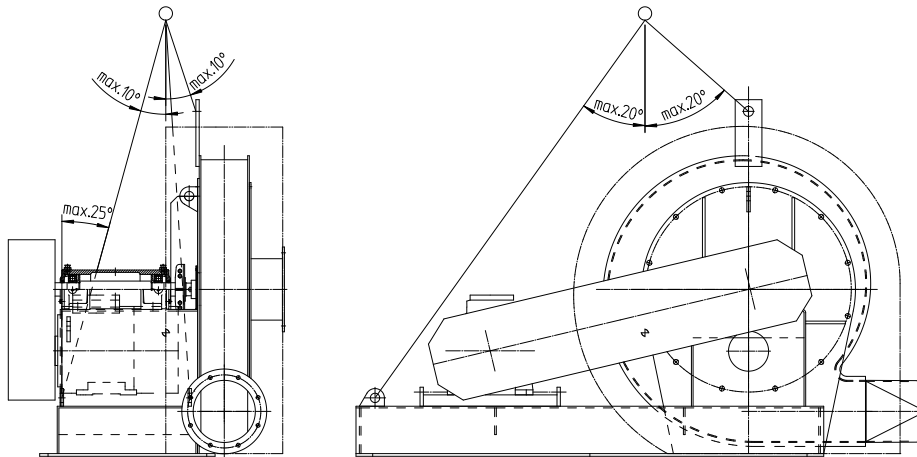

- The fans may only be lifted and transported by the fixtures provided for the purpose. Do not attach lifting tackle and slings to bearings, intake and pressure nozzles, motors or other components!
- Make sure that the weight is distributed evenly. The angle must not exceed 20° or 10° respectively! See the previous diagram.
- Care must be taken when lifting the fan to ensure that no parts get damaged by the lifting tackle and slings. Use a carriage if necessary!

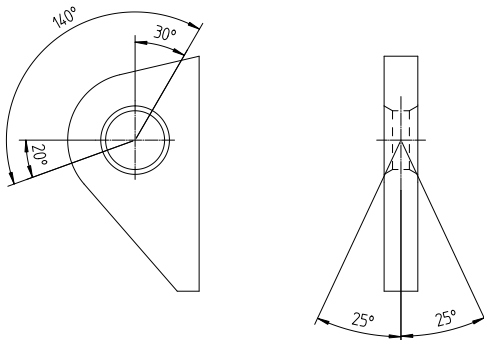

Permissible load directions

**13 Installation**

- For outdoor installation, the installation phase itself and any repair work undertaken outdoors, suitable measures must be taken to protect the fan against the elements.
- Check that the installation point is flat and clean.
- The installation tolerance for the alignment of the machine with

a greased bearing of max. 2 mm/m

must be observed.

- Immediate alignment is of critical importance to prevent damage to the bearings, vibrations and other defects!
- Strain on the fan at the connections caused by the pipe lines is not permitted and it is essential that this is prevented. Strain could cause changes in the gap on the nozzle. This is likely to lead to rubbing of the impeller nozzle and therefore an increased risk of explosion in explosive environments.
- If the machines are installed in a fixed position, the foundations must be expertly produced in accordance with DIN 4024, Part 2, and the machine secured in accordance with our recommendations. The requirements of DIN 18800 must be observed for all installations steel structures.
- Restoring forces from pipe lines must be restricted to a minimum, for example by using compensators. Where maximum loads for nozzles are specified in the dimension sheet, these must never be exceeded. Pipe lines must have specified fixed reference points.
This applies in particular to machines with media with a temperature over 100°C.
- The fan must be mounted on the foundations without strain.
- If installation is on vibration dampers, it is a requirement that compensators are fitted on the intake- and pressure-side flange. This also applies to all other supply lines to the fan (condensate drainage nozzles, steam and oil supply systems).
- Fasten vibration dampers at the intended points as shown in the installation layout drawing. If different types of vibration damper are used, make sure that these are arranged in accordance with the installation layout drawing.
- If it emerges during installation that the machine has a slight tilt, an adjustment plate has to be fitted to the appropriate vibration damper between the damper and the foundations.
- After completion of alignment, the dampers have to be secured to the foundations by screws or dowels. In certain cases it will be sufficient if just the corner dampers are secured.
- The fans may only be lifted and transported by the fixtures provided for the purpose.
- The fan and motor must be properly and expertly earthed via the earth connections (see the dimensions sheet) provided for the purpose.
- The fan components or supply systems must be capable of expanding freely in response to rising temperatures, without coming into contact with combustible substances or materials.

**14 Placing into operation / test run**

- No liability will be accepted for faults caused by inexperienced placing into operation by the customer.
- Check whether lubricants have been filled up. The bearings must not be started without lubrication!
- Only specified lubricants, or equivalent, may be used. Contamination is not permitted.
- Before placing into operation, check that there are no foreign bodies in the pipe lines or the fan housing.
- Foreign bodies are not permitted to enter the impeller.
- The surge-like entry of liquids into the impeller and inadequate removal of condensation from the fan housing must be prevented under all circumstances.
- Before the test run, check that the shaft is able to rotate easily and that the impeller moves freely (for explosion-protected fans, check and document the impeller gap).



An impeller gap ≥ 4 mm between the impeller nozzle and the housing nozzle must be observed all-round for explosion protection reasons!



Check the minimum seal gap of 2 mm on the shaft seal!

- Check the direction of rotation (there are direction arrows on the housing).
-
- Check that all mechanical and electrical safety equipment is properly fitted and installed.
- Check that the current type, voltage and frequency of the drive motor are suitable and that the connections have been made in accordance with the standards.
- Check that all guards have been correctly installed with original parts, including means of fastening.
- Lubrication of the bearings must be ensured by strict observance of lubrication regulations and regular maintenance, including checking the bearing temperatures.
- The materials and processing and operating materials used must be suitable for the intended use and must be compatible with the medium.



Before it is placed into operation, the fan must be fitted with one or more EMERGENCY STOP command devices for averting an immediate danger which has actually occurred or threatens to occur.

These devices must be clearly marked and must be accessible without difficulty at all times!

It must only be possible to release the EMERGENCY STOP command device by means of appropriate actuation. This release function must not cause the fan to be restarted; it may only make it possible for a restart to be carried out.

**15 Switching on the fan**

The fan may only be started up if the moment of acceleration is sufficient over the entire start-up range up to the rated speed!

Start up the fan with the flow restrictor closed.



Operation with a closed flow restrictor is only permissible during fan start-up. The flow restrictor must be opened quickly as soon as the final speed has been reached!

Check the following points during and after the start-up of the fan:

- * Power consumption
- * Voltage
- * Smooth running of the fan (vibrations)
- * Unusual running noise
- * Bearing temperatures
- * Compression heat on the fan housing



If any of the specified values are exceeded or the fan makes unusual noises, switch off the fan immediately and inform the manufacturer's service department.

16 Switching off the fan

Let the fan slow down to a stop without braking.



Observe safety regulations in accordance with DIN VDE 0105.



The fan must never be switched on again until the impeller has come to a complete standstill first. This is the only way of preventing negative torque shocks which could cause considerable damage to components such as bearings, impellers and couplings.

The fan is only permitted to be switched on and off by specialists who have been assigned to do so by the person responsible for the system.



17 Servicing and maintenance



Accident prevention regulations must be observed!

The usual mechanical engineering principles must be observed in relation to maintenance. Only suitably qualified personnel are permitted to carry out any maintenance and repair work.

The customer must ensure that there is sufficient space available for maintenance and repair work. This applies both in terms of service personnel and in terms of space for setting down parts of the fan such as impellers and the housing, etc. Furthermore, constructional measures have to be provided to enable these parts to be lifted and moved, e.g. crane tracks or beams for attaching chain hoists. The customer must also provide adequate lighting for servicing and maintenance work, and must also take suitable measures to prevent falling. Guide mandrels are to be used for maintenance and repair work.

Carry out maintenance and repair work using suitable protective equipment and tools only.



MANDATORY REQUIREMENT Wear ear protection!

Ear protection may have to be worn for work on the system, depending on the surrounding noise levels.



MANDATORY REQUIREMENT Wear safety footwear!

Safety footwear must be worn for all work on the system.



MANDATORY REQUIREMENT Wear gloves!

Suitable safety gloves must be worn for all work on the system.



MANDATORY REQUIREMENT Wear safety glasses!

Safety glasses have to be worn for work on the system, depending on the specific activity.



The fan needs to be checked every now and again for smooth running during operation. If the impeller does not run smoothly, it needs to be cleaned and possibly rebalanced.



Before you open the fan housing, undo a flange connection or remove the mesh guard, the fan must be switched off and measures taken to prevent it being switched on again. Make sure that the impeller is at a standstill.

Verify that it is disconnected from the power supply. Cover or safeguard adjacent live components.

Accident prevention regulations must be observed. All safety equipment must be re-installed before the fan is switched on again!

Check that all hot surfaces have cooled down sufficiently!

Risk of burn injuries caused by removing insulation or opening service openings too quickly.



If the system is shut down for any lengthy period of time (longer than 3 months), the rotor unit needs to be turned in 2-weekly cycles in order to ensure that the roller bearings are kept covered in lubricant and to prevent point loading of the roller bearings!



Harmful and hazardous residual substances in the machine must be taken into account!



Use suitable cleaning agents and equipment for cleaning work!



The use of high-pressure steam cleaners for cleaning the fan is not permitted!

It is imperative that moisture is prevented from getting into components such as bearings and seals, since this could lead to the development of corrosion.



After completion of maintenance and repair work, check that all solid and liquid foreign bodies have been removed from the fan and adjacent system components, that all openings have been closed, and that all mechanical and electrical safety equipment has been fitted back in place.

If any damage should occur in spite of observing all instructions and information, please report it immediately. The next steps, subject to agreement:

- * request for a service engineer, or
- * repair or production of a new one at our factory

The following inspections and maintenance work need to be carried out in a general service:

17.1 Motor

The motor manufacturer's instructions must be observed for all care and maintenance work on the motor.



If the electric motor is equipped with a re-lubrication device, the specific information on the plate attached to the motor must be observed!

17.2 Housing

Inspection of the housing (once a year) for the possible presence of:

- * Damage / cracks!

Water collects in the bottom part of the housing when the impeller is cleaned and as a result of condensation. This water has to be drained through the condensate drainage nozzle.

	Installation instruction for Karl Klein Radial Fan Apovent ATEX version	Page32 <div style="text-align: right;">  Version 07/2019 </div>
---	---	---

17.3 Impeller

Inspection of the impeller (once a year) for the possible presence of:

- * Wear
- * Damage / cracks!
- * Corrosion
- * Temper colours
- * Balancing weights (secure fastening, wear)!

The manufacturer must be informed if any unusual changes are found.

17.4 Shaft seal

Check the shaft seal (once a year) for:

- * Dirt
- * Wear or damage to the seal discs

Each shaft seal should be visually examined once a year during the fan inspection. If there is considerable play and therefore high leakage losses, the seal discs must all be replaced.

17.5 Disassembly/assembly of the impeller

We recommend having this work performed by our specialist personnel.

Work sequence	
Switch off the fan	
Remove the housing insulation from the area of the cover (if provided)	
Remove the cover screws and take off the cover	
Remove the thrust disc	
Screw in 4 threaded rods size M10 or M12 into the hub, hang the impeller on the crane or support in the housing and press off with the thrust disc (into which a forcing-off screw is screwed) or hydraulically.	
Assembly in reverse order	Apply Gleitmo 100 to the shaft Attention: A minimum shaft sealing gap of 2 mm and an impeller gap of ≥ 4.0 mm between the impeller nozzle and the housing nozzle must be observed all-round for explosion protection reasons. The installation layout drawing must be observed!



17.6 Drive via V-belt

17.6.1 Bearing

The bearing has to be removed after approx. 40,000 operating hours in order to remove the grease which has collected in the housing as a result of re-lubrication.

Re-lubrication interval: Every 3,000 h (min. twice a year)

Grease type: Shell Alvania RL3 or equivalent grease from another manufacturer

Type	Initial lubrication per bearing point [cm ³]	Re-lubrication per bearing point [cm ³]
ZLG.306	46	20
ZLG.308	103	36
ZLG.310	168	67
ZLG.312	243	108
ZLG.314	411	160
ZLG.316	590	227

17.6.2 Disassembly/assembly of the roller bearings

We recommend having this work performed by our specialist personnel.

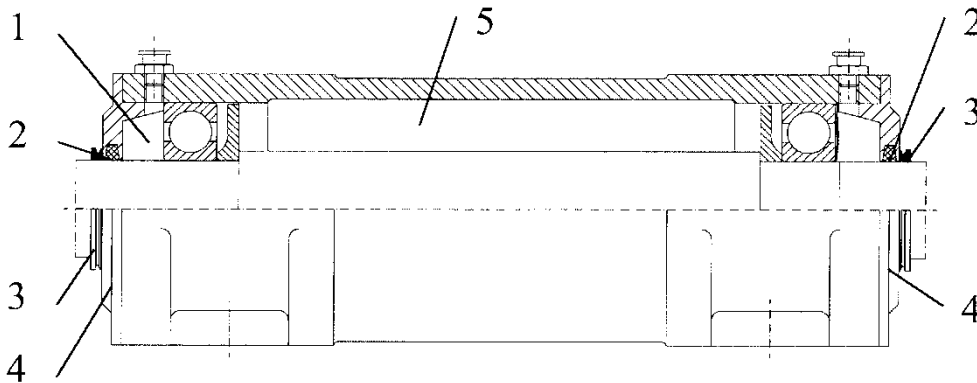

- | | | |
|-----------------|-------------|----------|
| 1 Spring washer | 2 Felt ring | 3 V-ring |
| 4 End face | 5 Shaft | |

ORIGINAL INSTALLATION INSTRUCTION



Installation instruction for
Karl Klein Radial Fan
Apovent ATEX version

Page34

GB

Version 07/2019

Work sequence	Note
Switch off the fan	
Pull off the belt pulley and the spacer sleeves. Unscrew the shaft seal.	
Undo the foot mounting screws and remove the bearing housing. Pull off the V-rings (3), which are fitted at the front end in front of the cover, from the shaft. Undo the cover and pull it from the shaft (5) and out of the housing. Pull the shaft (5) out of the housing.	
Use a pull-off device secured to the grease quantity control disc to pull the bearing from the shaft (5).	The pull-off device is not allowed to engage on the outer ring of deep-groove ball bearing or the roller bearing will be damaged.
Push the grease quantity control disk back onto both ends of the shaft (5) with the smoothly turned end facing the shaft shoulder.	
Wash out the housing with petroleum ether.	After washing out the housing with petroleum ether, dry it with compressed air.
Heat the new bearings in an oil bath to 90°C and push onto the shaft. If no oil bath is available, you should use an inductive heater and heat up the internal rings similarly to 90°C.	The heating temperature is not allowed to exceed 120°C. After you mount the roller bearings in front of the grease quantity control disc, fill the roller bearings with grease on both sides.
Carefully insert the shaft with the mounted bearings into the housing body.	
Push the cover onto the shaft (5). Screw the cover into the housing. Push the V-ring (3) back onto the shaft and press in front of the cover. Fit the fan seal and bearing housing.	
Pull on the belt pulley and impeller using the pull-in bolts – do not hit! Commissioning is performed with the quantity of grease which was inserted during assembly. Immediately after the first start-up, twice as much grease should be filled via the lubrication nipples as is normally needed for relubrication.	

17.6.3 Belt drive

Check the belt drive at regular intervals for:

- Wear
- Alignment
- Belt tension

If you need to re-tension or replace the belt, pay attention to the following:

1. Always replace the complete V-belt set, never just individual belts!
2. First slacken the belts, i.e. slacken the tensioning screws and the screws used to secure the motor. Shift the motor sufficiently to allow the belts to be removed and fitted without tension.
3. Fit the new belt set and pre-tension slightly. Check the parallelism of the belt pulleys with a ruler and correct if necessary.
4. The belts have to be tensioned enough for the specified thumb deflection depth to be achieved with the specified test force. The values apply to the individual belt. Afterwards, tighten the screws for securing the motor. The V-belts have to be re-tensioned after a running-in period of about 15 minutes. After three and ten days of operating conditions, the V-belts need to be checked again and re-tensioned again if necessary. The belt tension needs to be checked at greater intervals on a regular basis because slippage as a result of insufficient tension will lead to the premature destruction of the belt.
5. A belt testing device from a belt manufacturer must be used for testing and tensioning.



17.7 Drive via coupling

The bearing has to be removed after approx. 40,000 operating hours in order to remove the grease which has collected in the housing as a result of re-lubrication.

Re-lubrication interval: Every 3,000 h (min. twice a year)

Grease type: Shell Alvania RL3 or equivalent grease from another manufacturer.

Type	Initial lubrication per bearing point [cm ³]	Re-lubrication per bearing point [cm ³]
ZLG.306	46	20
ZLG.308	103	36
ZLG.310	168	67
ZLG.312	243	108
ZLG.314	411	160
ZLG.316	590	227

17.7.1 Coupling drive

The manufacturer's Installation instruction must be observed!

17.7.2 Disassembly/assembly of the roller bearings

We recommend having this work performed by our specialist personnel.

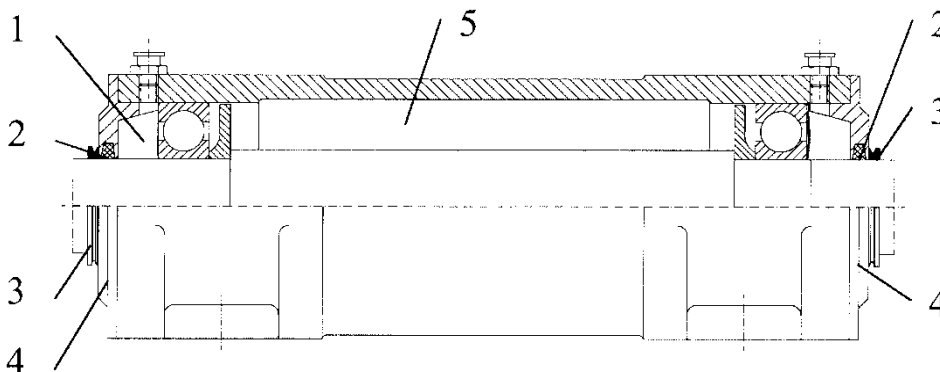

- | | | |
|---------------------|-----------------|--------------|
| 1 Spring washer | 2 Felt ring | 3 V-ring |
| 4 End face | 5 Shaft | |

ORIGINAL INSTALLATION INSTRUCTION



Installation instruction for
Karl Klein Radial Fan
Apovent ATEX version

Page36

GB

Version 07/2019

Work sequence	Note
Switch off the fan	
Pull off the coupling and impeller (see chapter 8.5) and the spacer sleeves. Unscrew the shaft seal.	
Undo the foot mounting screws and remove the bearing housing. Pull off the V-rings (3), which are fitted at the front end in front of the covers, from the shaft. Undo the cover and pull it from the shaft (5) and out of the housing. Pull the shaft (5) out of the housing.	
Use a pull-off device secured to the grease quantity control disc to pull the bearing from the shaft (5).	The pull-off device is not allowed to engage on the outer ring of deep-groove ball bearing or the roller bearing will be damaged.
Push the grease quantity control disk back onto both ends of the shaft (5) with the smoothly turned end facing the shaft shoulder.	
Wash out the housing with petroleum ether.	After washing out the housing with petroleum ether, dry it with compressed air.
Heat the new bearings in an oil bath to 90°C and push onto the shaft. If no oil bath is available, you should use an inductive heater and heat up the internal rings similarly to 90°C.	The heating temperature is not allowed to exceed 120°C. After you mount the roller bearings in front of the grease quantity control disc, fill the roller bearings with grease on both sides.
Carefully insert the shaft with the mounted bearings into the housing body.	
Push the cover onto the shaft (5). Screw the cover into the housing. Push the V-ring (3) back onto the shaft and press in front of the cover. Fit the fan seal and bearing housing.	
Pull on the coupling and impeller using the pull-in bolts – do not hit! Commissioning is performed with the quantity of grease which was inserted during assembly. Immediately after the first start-up, twice as much grease should be filled via the lubrication nipples as is normally needed for relubrication.	



17.8 Compensators with / without guide plate

If provided
During the optical check watch out for

- * discolouration of the external coating
- * Formation of bubbles
- * Embrittlement
- * Extreme kinks
- * Severe distortions
- * Layers of dust, sand etc.
- * Rubbing marks
- * Tension-free assembly!

When installing the compensator, make sure that the guide plate is installed pointing in the correct direction. The guide plate must be installed such that it tapers in the flow direction. The flange which is welded to the guide plate will be clamped between the pipe line flange and the compensator flange.

The mounting dimensions of the compensators must be observed!

17.9 Tightening torque

If no special tightening torque values are given in the installation layout drawing or in the dimensions sheet, the tightening torque values given in the following table apply:

Quality 8.8 Thread (Nom. diam)	20 °C		100 °C		200 °C		250 °C		300 °C	
	F _M (N)	M _a (Nm)	F _M (N)	M _a (Nm)	F _M (N)	M _a (Nm)	F _M (N)	M _a (Nm)	F _M (N)	M _a (Nm)
M 6	5930	8	5467	7	5004	7	4726	6	4448	6
M 8	10848	19	10000	18	9153	16	8644	15	8136	14
M 10	17236	38	15889	35	14543	32	13735	30	12927	28
M 12	25094	65	23134	60	21173	55	19997	52	18821	49
M 16	47117	155	43436	143	39755	131	37546	124	35338	117
M 20	73527	303	67782	280	62038	256	58592	242	55145	228
M 24	105938	523	97662	482	89385	441	84420	417	79454	392
M 30	168874	1042	155681	960	142488	879	134572	830	126656	781
M 36	246420	1805	227169	1664	207917	1523	196366	1439	184815	1354
M 42	338576	2885	312125	2659	285673	2434	269803	2299	253932	2163
M 48	445342	4342	410550	3558	375757	3664	354882	3460	334006	3256

The clamping force F_M gives the permissible bolting force, based on utilisation of the yield strength R_{p0.2} of 90%.
The tightening torque M_a is based on the method of tightening using a torque wrench, alpha=1.8 and a coefficient of sliding friction of 0.08 for the head and thread friction.

17.10 Checking the screw connections

All screw connections must be regularly checked to ensure that they are all in place and securely fastened, e.g.:

- * Screw connections on the housing
- * Screw connections on the compensators
- * Screw connections on the foundations
- * Fastening of the bearing housing/motor, etc.

17.11 Checking for leaks

Check the fan housing and connected pipe line for leaks and, if required:

- * Tighten the flange connection
- * Check the shaft seal and replace if necessary
- * Re-seal the joints



17.12 Storage and corrosion protection instructions

Karl Klein Ventilatorenbau GmbH does not specify any requirements as a general rule for corrosion protection for temporary storage at the building site. The customer needs to take appropriate measures of protection to provide protection against the elements.

If the fan is to be put into storage and provided with protection against corrosion for a temporary storage period of a **maximum of 3 months**, the following must be observed:

- * Close the intake and pressure opening
- * Protect machine parts without paintwork by applying conserving agent to them
- * To prevent damage to the bearings, the rotor unit needs to be turned every now and again.
- * Take appropriate measures (cover with foil or store in solid buildings) to protect the fan against the elements

If the fan is to be put into storage and provided with protection against corrosion for a temporary storage period of a **maximum of 6 months**, the following must be observed:

- * Ensure that it is protected from rain and frost
- * Close the intake and pressure opening
- * Protect machine parts without paintwork by applying conserving agent to them
- * To prevent damage to the bearings, the rotor unit needs to be turned every now and again.
- * To prevent moisture and wetness infiltrating from behind or gap corrosion where weld seams are not complete on both sides, apply a filler of suitable materials to seal any such points.
- * The surfaces of shafts and shaft nuts made of normal steel which do not have a protective coating must be given a covering coat of corrosion protection wax. The shaft has to be protected with a coating of oil-resistant lacquer in the bearing housing.
- * Shaft exits on bearings have to be wrapped with Denso tape (wax-soaked jute tape).
- * Stuffing boxes and packings have to be wrapped with Denso tape (wax-soaked jute tape) on the outside. A film of Molykote has to be applied to the mating surfaces of bushes which may be susceptible to corrosion.
- * The housings of fitted labyrinth shaft seals must be treated with a long-term preservative such as Tectyl No. 506.
- * Shaft exits on shaft seals have to be wrapped with Denso tape (wax-soaked jute tape).
- * Mechanically machined surfaces on impellers must be sealed with corrosion protection.
- * Corrosion protection must be applied to impellers without paintwork or other form of coating.
- * Corrosion protection wax must be applied to exposed bushes if they are made of non-rust-resistant materials.
- * Motors must be provided with protection against corrosion in accordance with the supplier's instructions.

If the fan is to be put into storage and provided with protection against corrosion for period of **more than 6 months**, the following must be observed:

- * The application of protective coatings with corrosion protection wax must be repeated.
- * Denso tape which is in place must be pressed on again with no gaps after racing the machine.

If there should be longer periods of standstill after placing into operation during the warranty period, Karl Klein Ventilatorenbau GmbH must be informed so that special instructions can be drawn up for protection against corrosion. If we are not informed, we cannot accept any claims under the guarantee for later damages resulting from improper storage.

17.12.1 Removal of protection against corrosion

Prior to placing into operation, the:

- * Denso tape
- * corrosion protection wax on mating surfaces and, depending on the process conditions, on the process side (e.g. fan housing),

have to be removed.

ORIGINAL INSTALLATION INSTRUCTION



Installation instruction for
Karl Klein Radial Fan
Apovent ATEX version

Page39

GB

Version 07/2019

18 Faults and troubleshooting

ATTENTION: The work described below must always be carried out by specialist personnel in compliance with the applicable safety regulations. To prevent damage caused by work which is carried out inexpertly, you should always have repair work carried out by our qualified specialist personnel.

Karl Klein Ventilatorenbau GmbH will not accept any warranty claims for damage caused by repair work carried out inexpertly.

Fault	Possible cause	Solution
The fan does not operate smoothly	Caking on the impeller	Clean the impeller. Attention: Clean the impeller only when it is at a standstill. The fan must be secured to prevent it starting up again during this time!
	The impeller is worn.	Replace the impeller.
	The impeller has become deformed as a result of thermal influences.	Replace the impeller.
	Strain on the fan as a result of uneven foundations.	Undo the foundation fasteners and level the foundations. Secure the fan again afterwards.
	Inexpertly adjusted/secured vibration dampers.	Correct the settings.
Medium escaping from the shaft seal.	The seal is faulty or worn.	Replace the seal.
Grinding noises on the fan.	Impeller rubbing against the intake nozzle.	Undo the housing cover and realign it; check the pipe line if necessary and correct it.
	Noises from the motor.	Check the motor for bearing damage; replace the bearing if necessary.
The power consumption given on the rating plate is permanently exceeded.	Excessive air flow.	Reduce the air flow with the assistance of a flow restrictor until the permissible power consumption level is achieved.
	Different speed for 60 Hz mains system.	Check the frequency.
The fan fails to start.	The drive motor is not connected correctly.	Check the connection.
	With a star-delta starter, the motor gets stuck in the star.	Reduce the switch-over time for star to delta.
	Starts up against insufficient system resistance.	Close the flow restrictors.
	The motor safety device is too weak.	The cross-sectional area of the cable and the safety equipment protect the starting current during start-up.
	The start-up time is too long.	Close the flow restrictors; check the torque M_A/M_N .
	The drive motor is faulty.	Check the motor and replace/repair if necessary.

	Installation instruction for Karl Klein Radial Fan Apovent ATEX version	<div style="display: flex; justify-content: space-between; align-items: center;"> <div style="text-align: center;"> <div style="border: 1px solid black; border-radius: 50%; padding: 5px; display: inline-block;"> GB </div> </div> <div style="text-align: left;"> Page40 Version 07/2019 </div> </div>
---	---	--

18.1 Drive via coupling

Bearing damage

Fault	Possible cause	Solution
Failure to operate smoothly Unusual running noise: Whining or whistling noise. Rattling or irregular noise. Gradual change in the running noise.	Damage to rings and rolling elements. Excessive bearing clearance. Wear as a result of dirt or insufficient lubrication Insufficient operational clearance. Unsuitable lubricant. Change in the operational clearance caused by temperature influences. Damage to the rolling surface (e.g. caused by dirt or fatigue)	Replace the bearing. Clean the bearing to remove dirt. Use clean grease or oil. Observe the intervals for changing the oil and re-lubricating. Use bearings with more operational clearance. Select the right type of lubricant. Protect bearings against temperature influences.

Coupling damage

Fault	Possible cause	Solution
Failure to operate smoothly Severe jolting during start-up	The coupling halves are not aligned. Elastic elements are worn. Elastic elements are too soft. Elastic elements are worn. The motor torque is too high M_A/M_N	Check the alignment in accordance with the instructions of the coupling manufacturer. Replace the elastic coupling elements. Use harder elastic coupling elements. Replace the elastic coupling elements. Star-delta starter



18.2 Drive via V-belt

Bearing damage

Fault	Possible cause	Solution
Failure to operate smoothly	Damage to rings and rolling elements. Excessive bearing clearance.	Replace the bearing.
	Wear as a result of dirt or insufficient lubrication	Clean the bearing to remove dirt. Use clean grease or oil. Observe the intervals for changing the oil and re-lubricating.
Unusual running noise: Whining or whistling noise.	Insufficient operational clearance.	Use bearings with more operational clearance.
Rattling or irregular noise.	Unsuitable lubricant.	Select the right type of lubricant.
Gradual change in the running noise.	Change in the operational clearance caused by temperature influences. Damage to the rolling surface (e.g. caused by dirt or fatigue)	Protect bearings against temperature influences.

Belt drive damage

Fault	Possible cause	Solution
Pronounced vibrations.	The belt is too loose or too tight.	Correct the tension of the belt.
Loud noises.	Impeller rubbing against a nozzle.	Correct the tension of the belt.
	The belt is too loose or too tight.	Correct the tension of the belt.
	Incorrect belt selection.	Replace the belt.
	The belt is oily or dirty.	Clean the belt or replace if necessary.
	The belt is worn.	Replace the belt.

**19 Disassembly**

Disassembly of the fan to relocate it to a different installation location or if it is to be scrapped.

For proper disassembly of the fan we recommend you to enlist the services of the manufacturer's assembly personnel. The disassembly of the fan may only be carried out by specialists who, on the basis of their professional training, experience and instruction, have sufficient knowledge of safety regulations, accident prevention regulations and generally recognised codes of practice (e.g. VDE guidelines, DIN standards). The specialists must be capable of assessing the work they have been assigned to do, recognising and preventing potential hazards, and be authorised to undertake the necessary work and activities by the individual responsible for the safety of the system.

20 Disposal

Parts and components of the fan which have reached the ends of their service lives, e.g. due to wear, corrosion, mechanical strain, fatigue and/or any other action which cannot be directly ascertained, have to be properly and correctly disposed of in accordance with national and international laws and regulations after disassembly. The same applies to all operating materials such as oil and grease or any other materials and substances. The conscious or unconscious reuse of used parts such as impellers, roller bearings, V-belts, etc., could pose a risk of danger to persons, harm to the environment and damage to plant and machinery.



Collect all oil, grease and cloths/cotton waste soiled with oil and grease in suitably marked containers and dispose of them in accordance with regulations.

**21 Spare parts**

Stocks of key spare parts and wearing parts need to be kept at the installation point of the system; this is a requirement for ensuring that the fan is always in proper working order and ready for operation.

We only offer a guarantee for the genuine spare parts supplied by us.

We explicitly point out that all spare parts and accessories not supplied by us have also not been tested and approved by us. The installation and/or use of such products can therefore, under certain circumstances, lead to negative changes in the specified constructional characteristics of the device or system and therefore result in the compromising of active and/or passive safety.

Karl Klein Ventilatorenbau GmbH will not accept any liability or warranty claims for damage caused by the use of non-genuine spare parts and accessories.

Please note that special production and supply specifications often apply to in-house parts or parts from other manufacturers and we always ensure that the spare parts we offer you are the state-of-the-art in technology and comply with the latest statutory requirements.

When you order spare parts, it is essential that you quote the

VA number
 Machine number
 Part name
 ID number
 Order quantity



when you do so.

The machine number can be found on the rating plate on the fan.

Please address all enquiries and orders to the following address:

Karl Klein Ventilatorenbau GmbH	Waldstr. 24 D-73773 Aichwald
Tel.: +49 711 36-906-0	
Fax: +49 711 36-906-950	Germany
E-mail: info@karl-klein.de	

	Installation instruction for Karl Klein Radial Fan Apovent ATEX version	<div style="border: 1px solid black; border-radius: 50%; width: 40px; height: 40px; display: flex; align-items: center; justify-content: center; margin: 0 auto;"> GB </div> Page44 Version 07/2019
---	---	---

22 EC-Declaration of incorporation of partly completed machinery



Karl Klein Ventilatorenbau GmbH
Waldstrasse 24
D-73773 Aichwald

Declaration of incorporation of partly completed machinery

According to Directive 2006/42/EC, Annex II part 1 B

This is to declare that the products:

Radial fans, Types: EEG... / DEG... / ENG... / DNG... / EMV... / DMV ... / EMVL.../ DMVL ... / ESV... / DSV... / EHV... / DHV..., all from year of manufacture 2010 on, NHV... / MHV... / HHV... / MVG... / TVG... / HF... / PF..., all from year of manufacture 2012 on, FLN... from year of manufacture 2019 on

as far as possible regarding our scope of delivery, generally comply with the directives as follows:

Council Directive 2006/42/EC (Machine Directive)

Furthermore effectual directives:

The safety objectives of the low voltage directive (2014/35/EC), accordingly annex I, No. 1.5.1 of the machine directive 2006/42/EC are fulfilled.

Note: For ATEX- types only exists a separate EC-Declaration of Conformity according ATEX Directive.

Note: There are separate declarations of conformity of the manufacturers for the electrical components.

Following harmonized standards were applied:

EN ISO 12100:2010
 EN 15085-2...-5:2007 Railway applications - Welding of railway vehicles and components – Certification degree CL2.
 Information: EN 15085 part 2 to 5:2007 ist maintained if it is agreed with an order only.

We furthermore declare, that the special technical documents for partly completed machinery were prepared according appendix VII part B and we commit to deliver these documents on demand to the commercial supervisory authorities.

Note: Initial operation of the incomplete machinery is prohibited as long as it is not installed into a complete machine which complies with the Council Directive 2006/42/EC and as long as the appropriate Declaration of Conformity according annex II A is not on hand.

The authorized person for the compilation of the technical documents is the subscriber.

City / date

Aichwald, july, 12th 2019

Signature and functioning of subscriber

Siegfried Seidler, Technical Manager

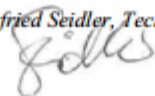

Annex

Followed Requirements of the annex I of 2006/42/EC. The figures are referring to paragraphs of annex I: 1.1.2, 1.1.3, 1.3.4, 1.7.4.2 (partly)

	Installation instruction for Karl Klein Radial Fan Apovent ATEX version	<div style="border: 1px solid black; border-radius: 50%; width: 40px; height: 40px; display: flex; align-items: center; justify-content: center; margin: 0 auto;"> GB </div> Page45 Version 07/2019
---	---	--

23 EC-Declaration of Conformity ATEX for the nonelectrical part



**Karl Klein Ventilatorenbau GmbH
 Waldstrasse 24
 D-73773 Aichwald**

EC-Declaration of Conformity





We hereby declare, that the products:

Radial Fans ENG..., DNG..., EMV..., DMV..., EMVL..., DMVL..., EHV..., DHV..., DSV..., EEG..., DEG..., NHV..., MHV..., HHV..., MVG..., TVG..., FLN..., HF..., PF...
All types of equipment group II, equipment category 2G, 3G, 2D und 3D, type of ignition protection „c“ (labeling „Ex h“)

Are developed, engineered and manufactured according following Directives:

ATEX-Directive 2014/34/EC

The labeling of the fans must include the following details:

- | | | |
|---------|---|---|
| |  | II (2 or 3)D Ex h IIIC T125°C D(b or c) |
| or |  | II (2 or 3)G Ex h II(B or C) T3 or T4 G(b or c) |
| or both | | |
| or |  | II 2/3G Ex h II(B or C) T3 or T4 G(b or c)
(= inside Cat. 2, outside Cat. 3) |
| or |  | II 3/2G Ex h II(B or C) T3 or T4 G(b or c)
(= inside Cat. 3, outside no ATEX zone) |

Following harmonized standards were applied:

- EN 1127-1:2011
- EN 80079-36:2017
- EN 80079-37:2016
- EN 14986:2017

Information: The plant manufacturer is responsible for fully compliance with the EN 14986:2017. The compliance with the EN 14986:2017 includes the assembled guard grid only, if it is part of our shipment.

Information: There are separate declarations of conformity of the manufacturers for the electrical components.

The technical documentation for fans of category 2G and 2D are deposited at following notified body: IBExU Institut für Sicherheitstechnik GmbH, Fuchsmühlenweg 7, D-09599 Freiberg.

The authorized person for the summary of the technical documents is the subscriber.

City, date

Aichwald, July 8th 2019

Signature and functioning of the subscriber

Siegfried Seidler, Head of Engineering

